

Door Thickness	Glass Thickness Max
1 3/4"	7/8"
1 3/8"	1/2"
2"	1 1/8"

Door Thickness \_\_\_\_\_ "

Glass Thickness \_\_\_\_\_ "

**Exposed Glass Size**

Moulding Removable  
One Side Only  
Screw Side, Check One

Push Side

Pull Side

**Cutout Size**

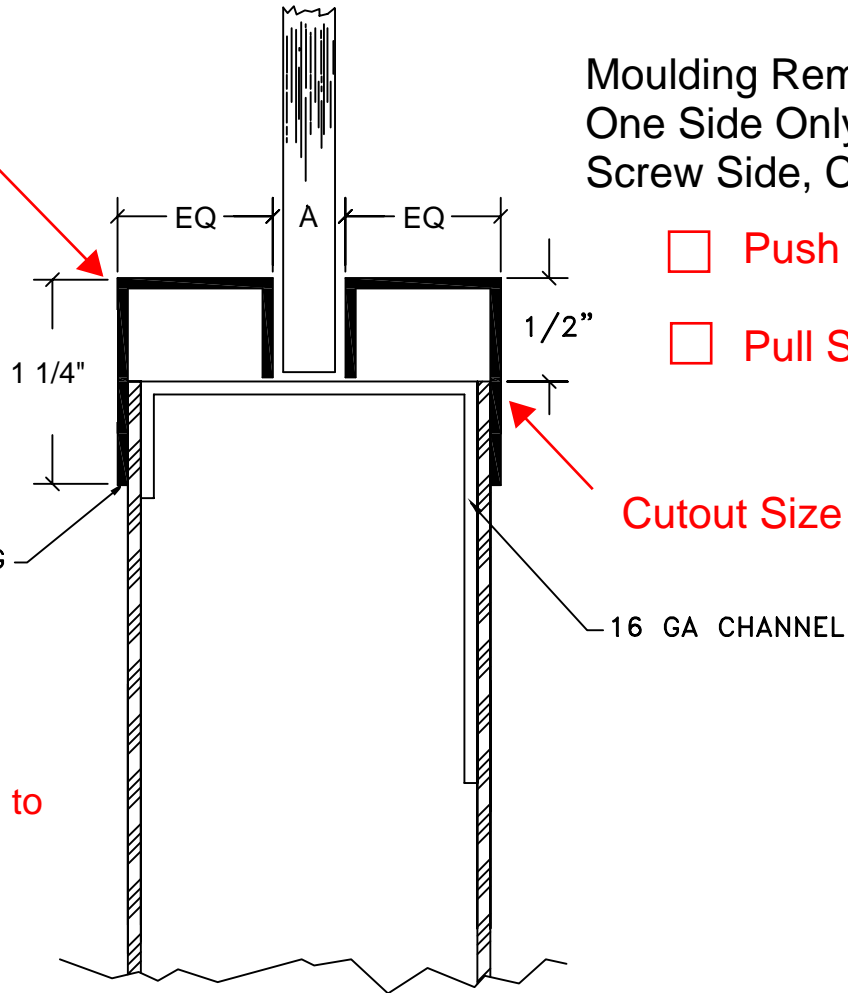

**Labeled Doors:**

- Minimum 5 3/4" Top & Vertical Rails to Cutout
- Minimum 6" Bottom Rail to Cutout

**Notes:**

- A (Gap) = Glass Thickness + 1/8"
- Cut Glass = Door Cut Out Less 1/4"
- Exposed Glass = Door Cut Out Less 1"
- Glazing by Others

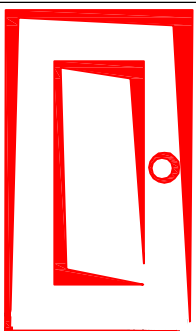

<p>Karpen Steel Custom Doors &amp; Frames</p> <p>181 Reems Creek Rd Weaverville NC 28787 www.karpensteel.com</p> <p>Tel: 828-645-4821 Fax: 800-851-2131</p> <p>Drawn/Revised by: <b>D SMITH</b></p>	<p>Title:</p> <p><b>Karpen Steel Low Profile Vision Lite Kit</b></p>
	<p>Description:</p> <p><b>For 1 3/8" to 2" Thick Doors</b></p>
	<p>File name:</p> <p><b>CUDV0001</b></p>
	<p>Rev. Date:</p> <p><b>19MAY09</b></p>
	<p>Revision</p>