

Door Thickness	Max Glass
1 3/4"	1 1/8"
1 3/8"	3/4"
2"	1 3/8"

Door Thickness _____"
Glass Thickness _____"

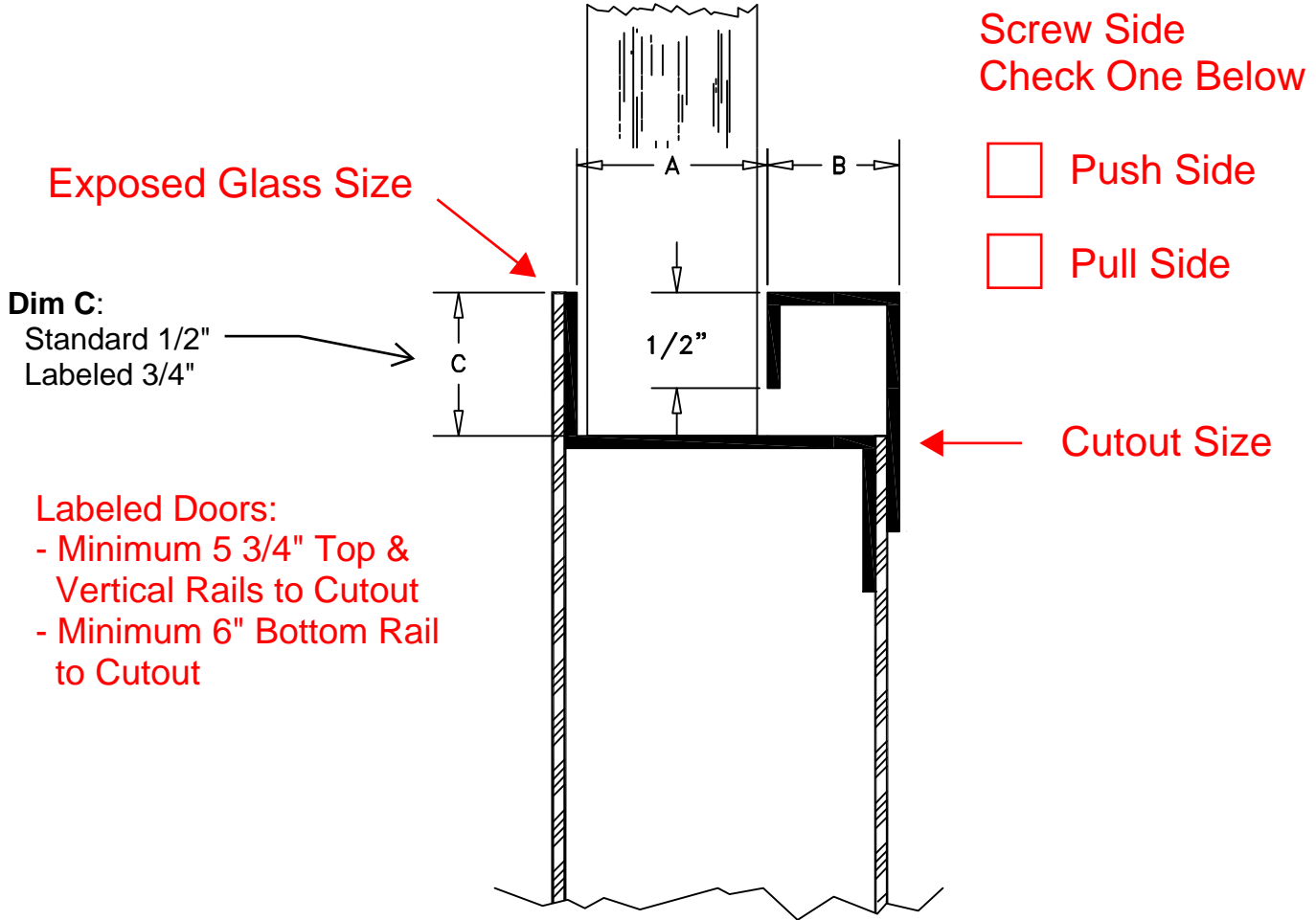

Notes:

- Cut Glass = Door Cut Out Less 1/4"
- Exposed Glass:
 - Standard C Dim 1/2" = Door Cut Out Less 1"
 - Labeled C Dim 3/4" = Door Cut Out Less 1 1/2"
- Glazing by Others
- A = Glass Thickness + 1/8"

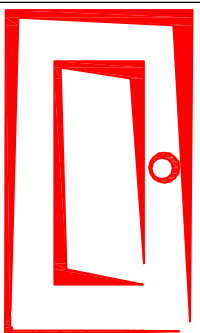

<p>Karpen Steel Custom Doors & Frames</p> <p>181 Reems Creek Rd Weaverville NC 28787 www.karpensteel.com</p> <p>Tel: 828-645-4821 Fax: 800-851-2131</p> <p>Drawn/Revised by: D SMITH</p>	<p>Title: Flush One Side Vision Lite Kit</p>
	<p>Description: Blade Stop for Very Thick Glass, Karpen Steel Low Profile Kit Opposite</p>
	<p>File name: CUDV0006</p>
	<p>Rev. Date: 21MAY09</p> <p>Revision</p>